

DICHIARAZIONE DI PRESTAZIONE

ai sensi del regolamento sui prodotti da costruzione (UE) N°.305/2011
N°: LE_09_0301_IT

- | | | |
|-----|--|--|
| 1. | Codice univoco di identificazione del tipo di prodotto | Giunto angolare
Dimensioni: vedere ETA-09/0301 |
| 2. | Numero di tipo, lotto, serie o altro elemento che consente l'identificazione del prodotto | ETA-09/0301
Numero di lotto: vedere Etichetta |
| 3. | Uso o usi previsti | Connettori per parti da costruzione in legno (travi principali e secondarie o supporti e travi secondarie) secondo ETA-09/0301 |
| 4. | Indirizzo di contatto del produttore | BB Stanz- und Umformtechnik GmbH
Nordhäuser Str. 44
06536 Berga
Germany |
| 5. | Sistema o sistemi di valutazione e verifica della costanza della prestazione del prodotto | Sistema 2+ |
| 6. | Documento di riferimento | ETA-09/0301 |
| 7. | Organismo/Numero EOTA | Deutsches Institut für Bautechnik, Berlin |
| 8. | Effettuate mediante l'organismo di certificazione | - Ispezione iniziale dello stabilimento di produzione e controllo della produzione in fabbrica
- Sorveglianza, valutazione e verifica continue
- Risultato del certificato di conformità 0769-CPD-6030 |
| 9. | Prestazione dichiarata | Vedere ETA-09/0301 |
| 10. | La prestazione del prodotto di cui al punto 1 e 2 è conforme alla prestazione dichiarata al punto 9. Si rilascia la presente dichiarazione di prestazione sotto la responsabilità esclusiva del fabbricante di cui al punto 4. | |

Firmato da e per conto del produttore da:



Günther Blesch
(amministratore delegato)
Berga, 16.01.2017

Approval body for construction products
and types of construction

Bautechnisches Prüfamt

An institution established by the Federal and
Laender Governments



European Technical Assessment

ETA-09/0301
of 25 January 2019

English translation prepared by DIBt - Original version in German language

General Part

Technical Assessment Body issuing the
European Technical Assessment:

Deutsches Institut für Bautechnik

Trade name of the construction product

BB-beam connectors

Product family
to which the construction product belongs

Three-dimensional nailing plates (BB-connector for wood
to wood connections)

Manufacturer

BB Stanz- und Umformtechnik GmbH
Nordhäuser Straße 42
06536 Berga
DEUTSCHLAND

Manufacturing plant

BB Stanz- und Umformtechnik GmbH
Nordhäuser Straße 42
06536 Berga
DEUTSCHLAND

This European Technical Assessment
contains

17 pages including 4 annexes which form an integral part
of this assessment

This European Technical Assessment is
issued in accordance with Regulation (EU)
No 305/2011, on the basis of

ETAG 015,
used as EAD according to Article 66 Paragraph 3 of
Regulation (EU) No 305/2011.

This version replaces

ETA-09/0301 issued on 25 June 2013

The European Technical Assessment is issued by the Technical Assessment Body in its official language. Translations of this European Technical Assessment in other languages shall fully correspond to the original issued document and shall be identified as such.

Communication of this European Technical Assessment, including transmission by electronic means, shall be in full. However, partial reproduction may only be made with the written consent of the issuing Technical Assessment Body. Any partial reproduction shall be identified as such.

This European Technical Assessment may be withdrawn by the issuing Technical Assessment Body, in particular pursuant to information by the Commission in accordance with Article 25(3) of Regulation (EU) No 305/2011.

Specific Part

1 Technical description of the product

BB-beam connectors are two-piece non-welded timber connectors. They are fastened to the timber construction elements with screws and used for connecting the timber construction elements with each other. They are installed as connections between wood based members according to Annex 2.

The connectors are made in different sizes of cold-formed galvanized steel sheet S250GD+Z275 according to EN 10346¹. Dimensions, hole positions, arrangement of fasteners and typical installations are shown in Annex 1 and in Annex 4. The beam connectors are made of steel sheets with tolerances according to EN 10143².

2 Specification of the intended use in accordance with the applicable European Assessment Document

The beam connectors are used for connecting the timber construction elements (header and joist or column and joist). The structural behaviour of the construction elements and the support conditions correspond to the indications given in Annex 3.

The beam connectors are used in timber structures subject to climate conditions defined by service classes 1 and 2 according to EN 1995-1-1³.

The performances given in Section 3 are only valid if the BB-beam connectors are used in compliance with the specifications and conditions given in Annex 1 to 4.

The verifications and assessment methods on which this European Technical Assessment is based lead to the assumption of a working life of the BB-beam connectors of at least 50 years. The indications given on the working life cannot be interpreted as a guarantee given by the producer, but are to be regarded only as a means for choosing the right products in relation to the expected economically reasonable working life of the works.

3 Performance of the product and references to the methods used for its assessment

3.1 Mechanical resistance and stability (BWR 1)

Essential characteristic	Performance
Load-carrying capacity	See Annex 3
Stiffness	No performance assessed
Ductility in cyclic testing	No performance assessed
Durability	See Annex 2

3.2 Safety in case of fire (BWR 2)

Essential characteristic	Performance
Reaction to fire	Class A1
Resistance to fire	No performance assessed

¹ EN 10346:2009 Continuously hot-dip coated steel flat products -Technical delivery conditions
² EN 10143:2006 Continuously hot-dip coated steel sheet and strip – Tolerances on dimensions and shape
³ EN 1995-1-1 + AC:2006 + A1:2008 Eurocode 5: Design of timber structures; Part 1-1: General – Common rules and rules for buildings

3.3 Hygiene, health and the environment (BWR 3)

Essential characteristic	Performance
Release of dangerous substances	No performance assessed

4 Assessment and verification of constancy of performance (AVCP) system applied, with reference to its legal base

In accordance with ETAG 015 the applicable European legal act is: [97/638/EC (EU)].
The system to be applied is: 2+

5 Technical details necessary for the implementation of the AVCP system, as provided for in the applicable EAD

Technical details necessary for the implementation of the AVCP system are laid down in the control plan deposited with Deutsches Institut für Bautechnik.

Issued in Berlin on 25 January 2019 by Deutsches Institut für Bautechnik

BD Dipl.-Ing. Andreas Kummerow
Head of Department

beglaubigt:
Baumann

Annex 1 Technical description of the product

Fastener types and sizes

Screw diameter [mm]	Length [mm] Min – max	Type
5.0	80 - 120	Screws according to EN 14592 with a minimum thread length of 72 mm
Values of strength		
Characteristic value of yield moment $M_{y,k} \geq 5900 \text{ Nmm}$		
Characteristic value of withdrawal parameter $f_{ax,k} \geq 10 \text{ N/mm}^2$ in timber with a characteristic density $\rho_k = 350 \text{ kg/m}^3$		

BB-beam connector 90x70

Two-piece connector consisting of a joist plate and suitable header plate of 3.0 mm thick, galvanized steel sheet S250GD+Z275 according to EN 10346 with a tolerance according to EN 10143

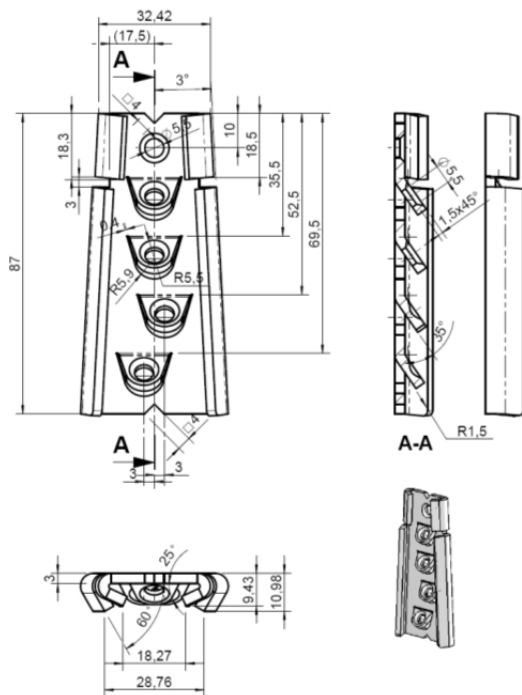

Figure A.1 Header plate of the Joist plate of the beam connector 90 x 70

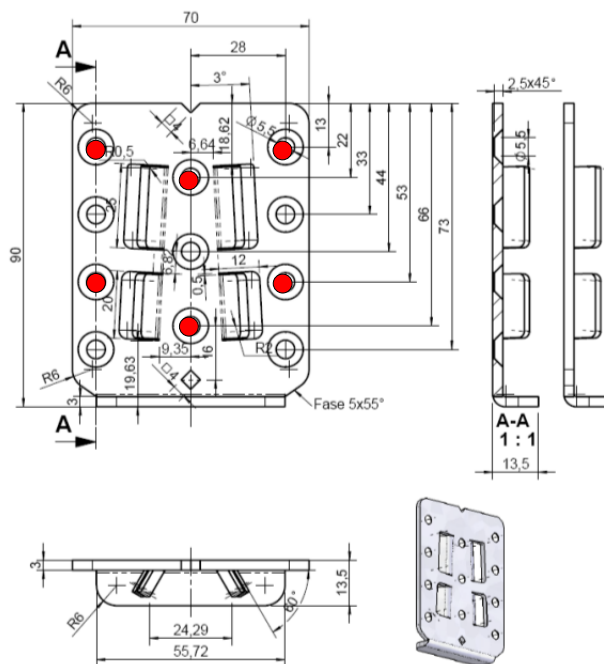

Figure A.2 beam connector 90 x 70
(● screws for column connection)

BB-beam connector 125x70

Two-piece connector consisting of a joist plate and suitable header plate of 3.0 mm thick galvanized steel sheet S250GD+Z275 according to EN 10346 with a tolerance according to EN 10143

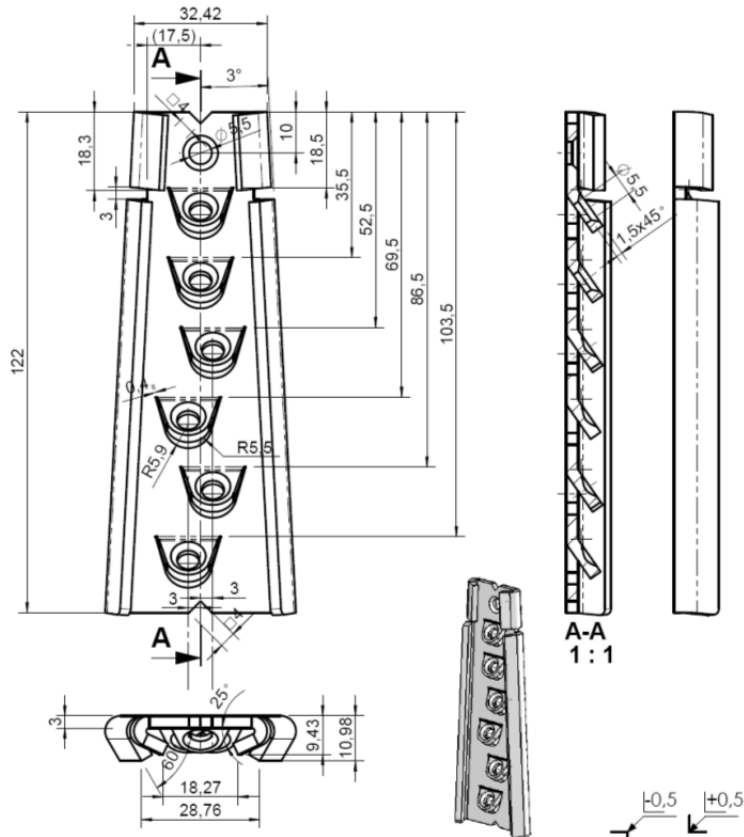

Figure A.3 Joist plate of the beam connector 125 x 70

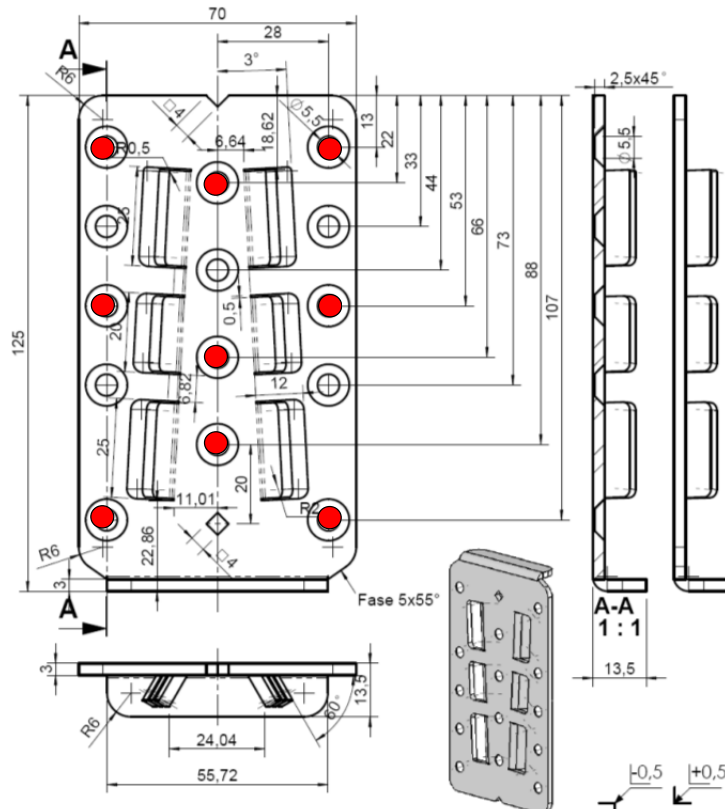

Figure A.4 Header plate of the beam connector 125 x 70 (● screws for column connection)

BB-beam connector 150x70

Two-piece connector consisting of a joist plate and suitable header plate of 3.0 mm thick, galvanized steel sheet S250GD+Z275 according to EN 10346 with a tolerance according to EN 10143

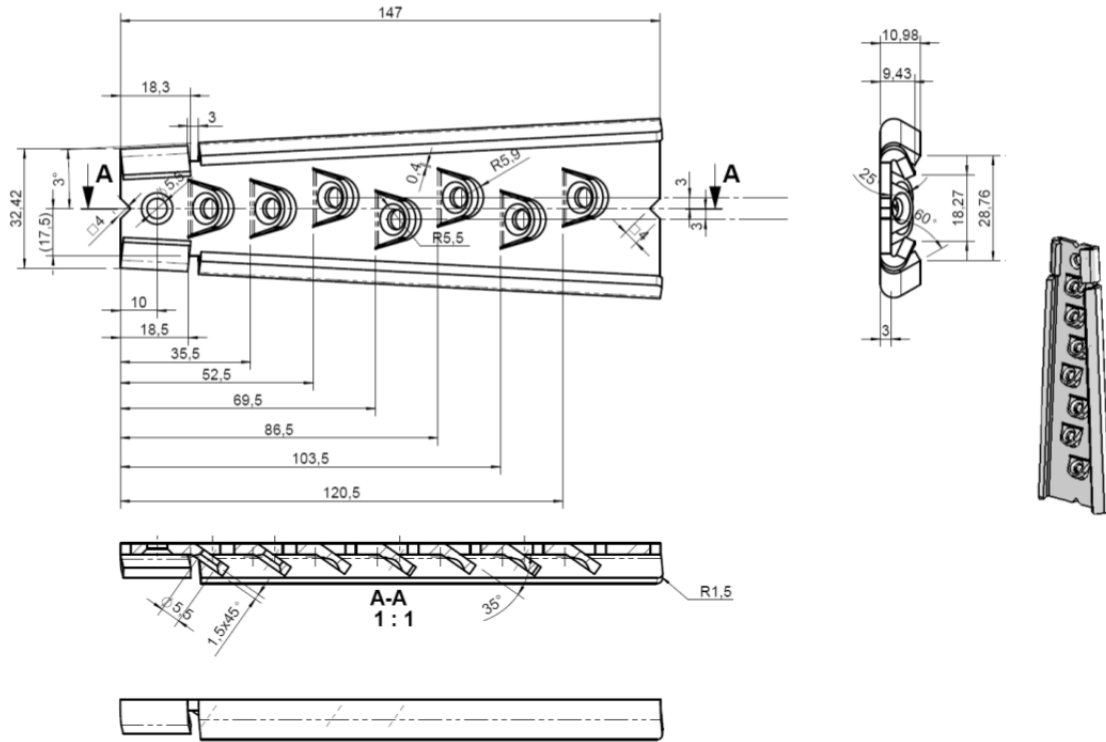

Figure A.5 Joist plate of the beam connector 150 x 70

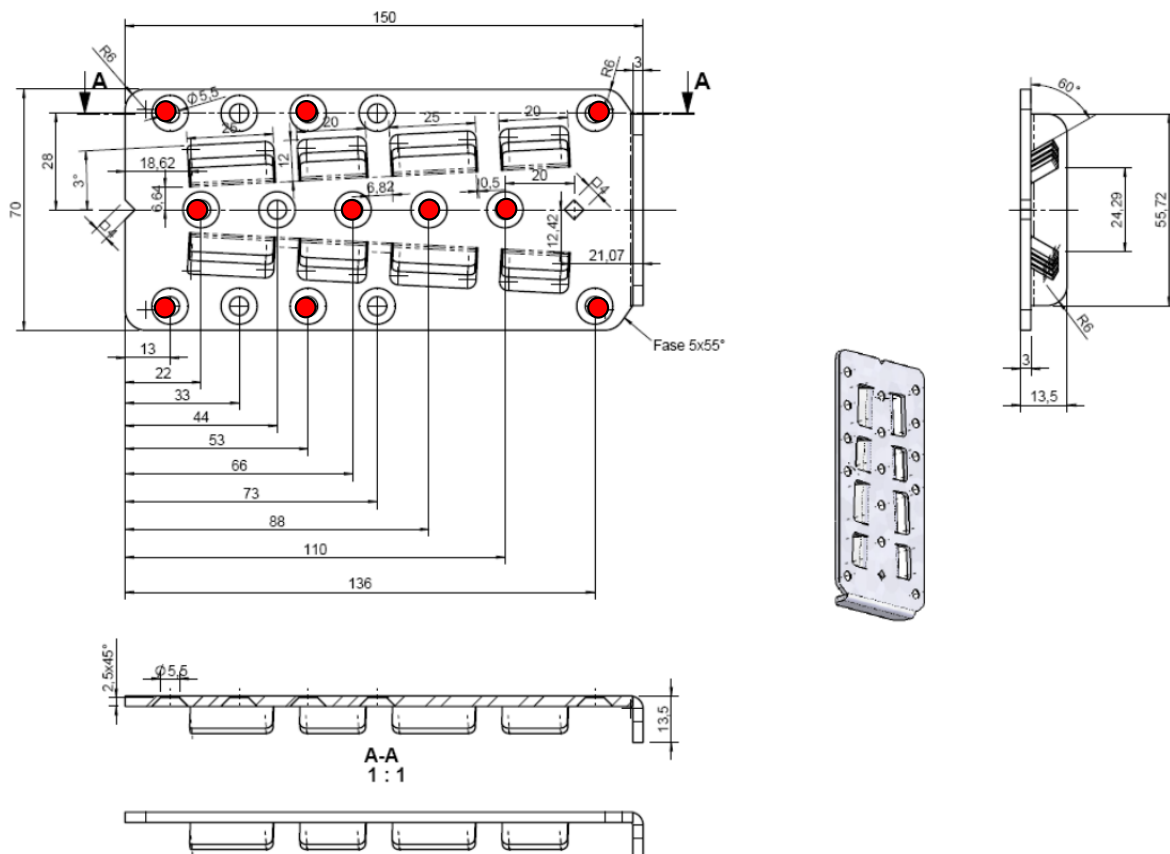

Figure A.6 Header plate of the beam connector 150 x 70 (● screws for column connection)

BB-beam connector 190x70

Two-piece connector consisting of a joist plate and suitable header plate of 3.0 mm thick, galvanized steel sheet S250GD+Z275 according to EN 10346 with a tolerance according to EN 10143

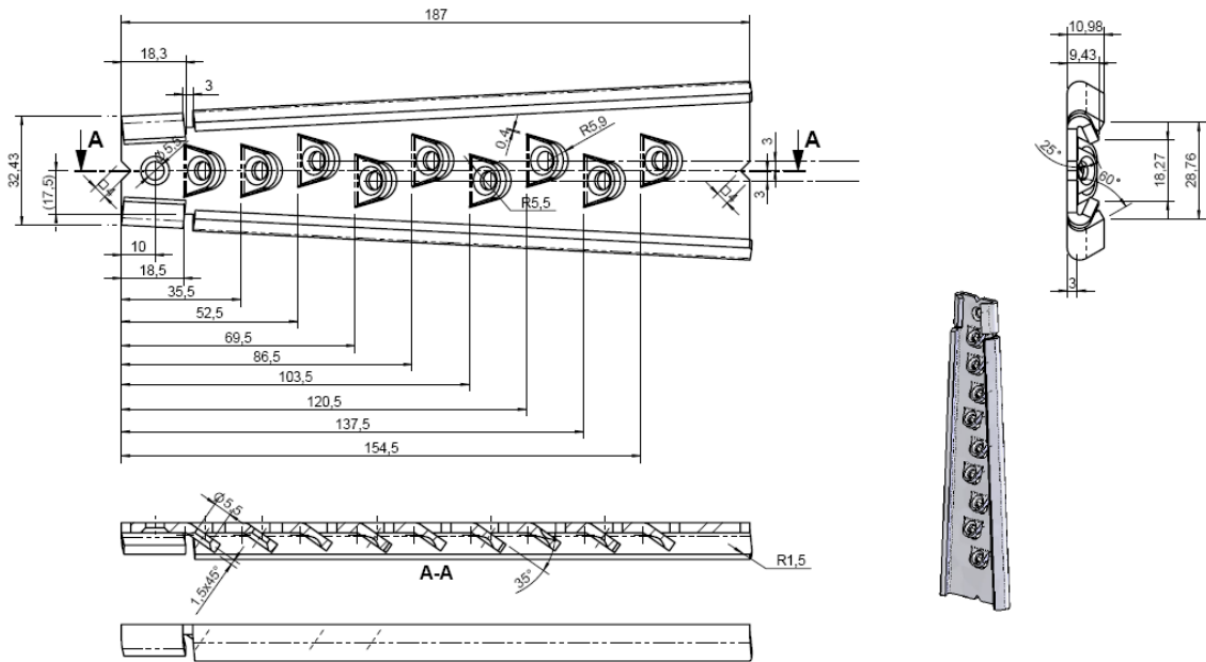

Figure A.7 Joist plate of the beam connector 190 x 70

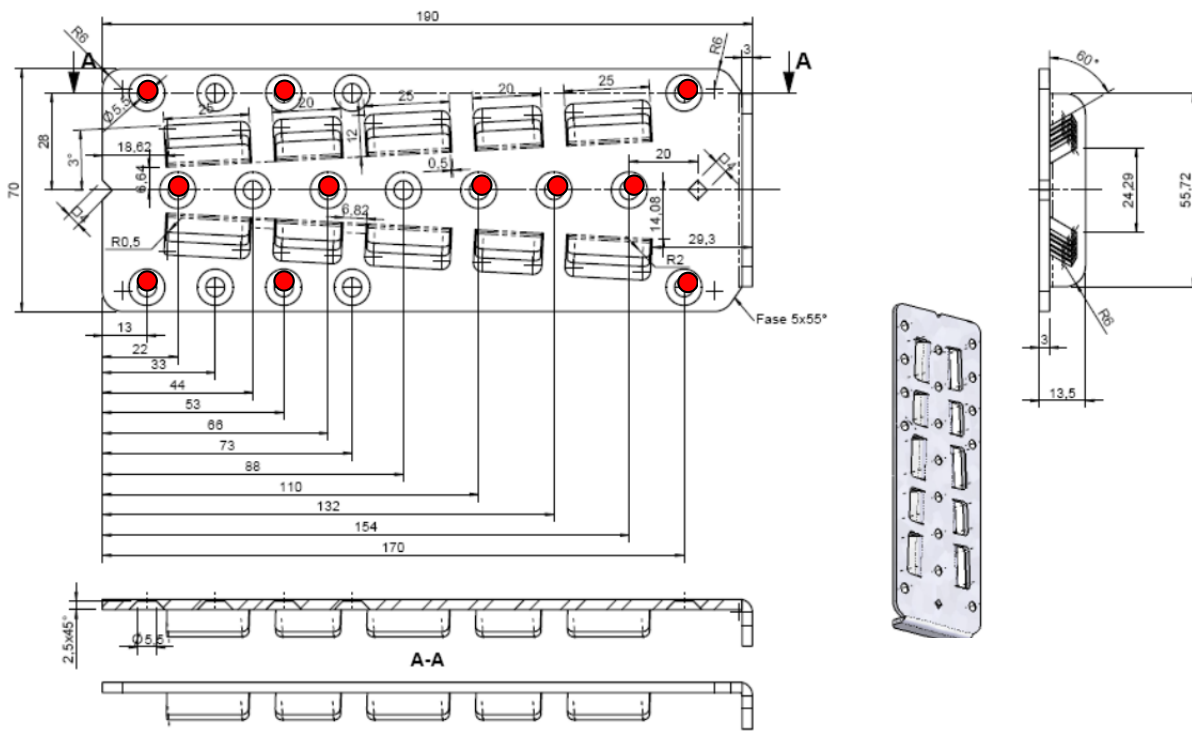

Figure A.8 Header plate of the beam connector 190 x 70 (● screws for column connection)

Annex 2 Specifications of intended use

A.2.1 Loading

- Static and quasi-static loads (not relevant to fatigue)
- Only for connections on torsion-resistant headers and headers sufficiently secure against rotation

A.2.2 Base material

The structural behaviour of the construction elements and the support conditions correspond to the indications given in Annex 3.

BB-beam connectors are installed as connections between the following wood based members:

- Solid timber (softwood) of strength classes C14 – C40 according to EN 338¹ / EN 14081-1²,
- Glued laminated timber of at least strength class GL24c according to EN 14080³,
- Laminated veneer lumber LVL according to EN 14374⁴ (only header or column), connection only perpendicular to the plane of the veneers,
- Parallel strand lumber Parallam PSL (only header or column), connection only perpendicular to the plane of the veneers,
- Laminated strand lumber Intrallam LSL (only header or column), connection only perpendicular to the plane of the veneers,
- Plywood according to EN 636⁵ and EN 13986⁶ (only header),
- Oriented Strand Board (OSB) according to EN 300⁷ and EN 13986 (only header),
- Glued solid timber according 14080,
- Solid wood panels according to EN 13353⁸ and EN 13986.

A.2.3 Use conditions (Environmental conditions)

A.2.3.1 Corrosion protection in service classes 1 and 2

BB-beam connectors are made of galvanized steel sheets of type S250GD+Z250 according to EN 10346⁹.

The screws used with the BB-beam connectors are of uncoated steel for service class 1 and 2 (in accordance with EN 1995-1-1:2010-12¹⁰, Table 4.1 if there is no special corrosive condition).

A.2.3.2 Wood preservative

If preservative treatment of timber is used national regulations will apply.

1	EN 338:2016	Timber structures - Strength classes
2	EN 14081-1:2016	Timber structures - Strength graded structural timber with rectangular cross section - Part 1: General requirements
3	EN 14080:2005	Timber structures - Glued laminated timber - Requirements
4	EN 14374:2004	Timber structures - Structural laminated veneer lumber - Requirements
5	EN 636:2012	Plywood - Specifications
6	EN 13986:2004	Wood-based panels for use in construction - Characteristics, evaluation of conformity and marking
7	EN 300:2006	Oriented Strand Boards (OSB) – Definitions, classification and specifications
8	EN 13353:2008+A1:2011	Solid wood panels (SWP) - Requirements
9	EN 10346:2015-10	Continuously hot-dip coated steel flat products for cold forming – Technical delivery conditions
10	EN 1995-1-1:2004+A1:2008+A2:2014	Eurocode 5: Design of timber structures – Part 1-1: General - Common rules and rules for buildings

BB-beam connectors

Specifications of intended use

Loading, base material, corrosion protection and wood preservative, installation

Annex 2.1

A.2.3.3 Installation

The connection with BB-beam connectors is deemed fit for its intended use provided:

The connection of the connectors to the construction elements is carried out at the factory. The connectors and the timber elements connected with that are classified according to Annex 4.

The header or columns are free from wane under the joist plate.

If the header carries a joist only on one side the eccentricity moment from

$M_v = F_J (B_H / 2)$ is considered at the strength verification of the header and its supports.

Where: F_J Reaction force from the joist

B_H Width of header

The same applies when the header has connections on both sides but with forces which differ more than 20 %.

BB-beam connectors are fastened to joists and headers or columns by screws according to Table in Annex 1.

All holes on joists and headers are supplied with screws. The arrangement of the screws for the connection to columns is shown in the product drawings.

Splitting of the header or joist caused by tensile forces perpendicular to the grain are considered in calculation.

BB-beam connectors are only used for connections on torsion-resistant headers and headers sufficiently secured against rotation.

The gap between the side grain of the header and the header plate of the connector as well as the gap between the joist plate and the header plate and the gap between the end grain of the joist and the joist plate are limited. Any of these gaps are maximum 1 mm. The joists and the connectors are installed strain-free, if suitable calculation is not carried out.

For BB-beam connectors the width of the header or column is at least equal to the screw length. In case of two-sided connections the width of the header or columns are at least $l+4d$, where l is the length and d the diameter of the screws in the header or column. For the connectors the depth of the joist allows an edge distance of at least 10 mm between the screw tip and the adjacent joist surface.

The width of the joist allows an edge distance of at least 12.5 mm between the side surfaces of the joist and the adjacent connector edges. The adjacent connector edges and the depth of the joist allow an edge distance of at least 15 mm between the top and bottom surfaces of the joist and the adjacent connector edges.

The header or columns have a plane surface against the whole beam connector.

The requirements to the timber members being joined are taken into account.

BB-beam connectors	Annex 2.2
Specifications of intended use	
Installation	

Annex 3 Specification of essential characteristics

Acting forces in a connection of BB-beam connectors

The forces acting in connection with the beam connectors are the following F_x , F_y and F_z , as shown in figure 3.1. The forces F_x and F_z are acting in the symmetry plane of the beam connector. The force F_y is acting with the distance e_j above the center of gravity of the nail connection at the joist. It is assumed that the line of action of the force is acting directly at the end of the joist.

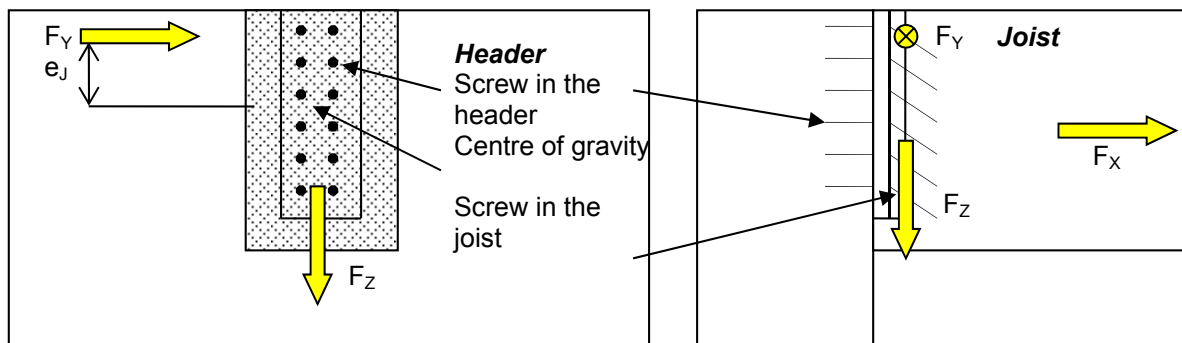

Figure 3.1: Acting forces in a connection with BB-beam connectors

In case of a one-sided connection of beam connectors the eccentricity moment exposing the header on torsion or the column on bending is taken into account when verifying the header and its supports or the column. In case of two-sided connections, where the reaction forces F_N of opposing joists do not differ more than 20%, the eccentricity moment may be neglected.

A.3.1 Design values of the load-carrying-capacities of BB-beam connector connections

The forces $F_{x,Ed}$ and $F_{z,Ed}$ act in the symmetry plane of the beam connector. The force $F_{y,Ed}$ acts in a distance e_j of the centre of gravity of the joist connection. It is assumed that the forces $F_{y,Ed}$ and $F_{z,Ed}$ are acting right at the end of the joist.

The header is secured against rotation around its own axis. If the connection is carried out on one side of the header or the column only, the eccentricity moment or the bending moment is taken into account. This applies accordingly, if the reaction forces on both sides of the header differ by more than 20 %.

In case of connections to headers all holes of the header plate shall be provided with screws, in case of connections to columns only the marked holes.

The width of the header or columns is at least equal to the screw length, in case of two-sided connections the width is at least $l + 4d$, where l is the length and d the diameter of the screws in the header connection. The distance between the screw tip and the adjacent joist surface shall be at least 10 mm.

For the calculation of design values, the partial material factor and the modification factor for timber or wood-based members are used.

BB-beam connectors	Annex 3.1
Specification of essential characteristics	
Design values of load-carrying-capacities	

A.3.1.1 Design values of the load-carrying-capacities

Design values for the following force directions may be calculated according to equation B.1 to B.4:

Force direction perpendicular to the connector plates:

$$F_{X,Rd} = \min \left\{ \begin{array}{l} \frac{A}{\gamma_{M,S}} \\ \frac{B_X \cdot k_p \cdot k_{mod}}{\gamma_{M,T}} \end{array} \right. \quad (B.1)$$

Force direction lateral:

$$F_{Y,Rd} = \frac{B_Y \cdot k_p \cdot k_{mod} \cdot k_e}{\gamma_{M,T}} \quad (B.2)$$

Force direction downward:

$$F_{Z,Rd} = \frac{B_Z \cdot k_p \cdot k_{mod}}{\gamma_{M,T}} \quad (B.3)$$

Force direction upward:

$$F_{Z,R,d} = 0 \quad (B.3a)$$

Combined loading:

$$\left(\frac{F_{X,Ed}}{F_{X,Rd}} \right)^2 + \left(\frac{F_{Y,Ed}}{F_{Y,Rd}} \right)^2 + \left(\frac{F_{Z,Ed}}{F_{Z,Rd}} \right)^2 \leq 1 \quad (B.4)$$

Where:

A, B_X, B_Y and B_Z are constants in kN (see Table 3.1),

γ_{M,S} Partial safety factor for steel in bending,

γ_{M,T} Partial safety factor for timber or wood-based material,

k_p Factor taking into account the characteristic density of joist or header/column,

$$k_p = \sqrt{\frac{\rho_k}{350}}$$

ρ_k Lower characteristic density of joist or header/column in kg/m³; ρ_k ≤ 460 kg/m³,

k_{mod} Modification factor to consider the load duration influence and the wood moisture,

k_e Factor taking into account the eccentricity of the load F_{Y,Ed},

$$k_e = \frac{1}{1 + \frac{6 \cdot e_J}{\ell}}$$

e_J Eccentricity of the force F_{Y,Ed} with regard to the centroid of the joist connection in mm (see Figure 3.1),

ℓ Connector length; 90 mm ≤ ℓ ≤ 190 mm.

BB-beam connectors	Annex 3.2
Specification of essential characteristics	
Design values of load-carrying-capacities	

Table 3.1: Constants A, B_X, B_Y and B_Z

Type	90x70	125x70	150x70	190x70
A [kN]	2.43	3.79	4.87	6.22
B _X [kN]	3.79	5.46	6.27	7.86
B _Y [kN]	5.15	7.73	9.02	11.6
B _Z [kN]	8.78	12.6	14.5	18.2

Splitting

If tensile stress perpendicular to the grain has to be proved, it can be carried out according to EN 1995-1-1, clause 8.1.4.

A.3.1.2 Design value of the load-carrying-capacity - Example

Beam connector Type 125x70

service class: 1/2

load-duration class permanent

- Force direction perpendicular to the connector plates:

$$F_{X,Rd} = \min \left\{ \begin{array}{l} A \\ \frac{B_X \cdot k_p \cdot k_{mod}}{\gamma_{M,T}} \end{array} \right. \quad (B1)$$

with:

$$A = 3.79 \text{ (}\xi \text{ (see table 3.1))}$$

$$\gamma_{M,S} = 1.3$$

$$B_X = 5.46 \text{ (s (see table 3.1))}$$

$$k_p = \sqrt{\frac{\rho_k}{350}} = \sqrt{\frac{385}{350}} = 1.049$$

$$k_{mod} = 0.6 \text{ (service class: 1 / 2; load-duration class: permanent)}$$

$$\gamma_{M,T} = 1.3$$

$$F_{X,Rd} = \min \left\{ \begin{array}{l} \frac{3.79}{1.3} = 2.92 \text{ kN} \\ \frac{5.46 \cdot 1.049 \cdot 0.6}{1.3} = 2.64 \text{ kN} \end{array} \right.$$

design value $F_{X,RD} = 2.64 \text{ kN}$

BB-beam connectors

Specification of essential characteristics

Design values of load-carrying-capacities – Example of calculation

Annex 3.3

- Force direction lateral:

$$F_{Y,Rd} = \frac{B_Y \cdot k_p \cdot k_{mod} \cdot k_e}{\gamma_{M,T}} \quad (B2)$$

with:

$$B_Y = 7.73 \text{ (}\epsilon \text{ (see table 3.1))}$$

$$k_p = \sqrt{\frac{\rho_k}{350}} = \sqrt{\frac{385}{350}} = 1.049$$

$$k_{mod} = 0.6 \text{ (service class: 1 / 2; load-duration class: permanent)}$$

$$k_e = \frac{1}{1 + \frac{6 \cdot e_j}{l}} = \frac{1}{1 + \frac{6 \cdot 60}{125}} = 0.258$$

$$e_j = 60 \text{ mm (assumed)}$$

$$\gamma_{M,T} = 1.3$$

$$F_{Y,Rd} = \frac{7.73 \cdot 1.049 \cdot 0.6 \cdot 0.258}{1.3} = 0.97 \text{ kN}$$

design value $F_{Y,RD} = 0.97 \text{ kN}$

- Force direction downward:

$$F_{Z,Rd} = \frac{B_Z \cdot k_p \cdot k_{mod}}{\gamma_{M,T}} \quad (B3)$$

with:

$$B_Z = 12.6 \text{ (s (see table 3.1))}$$

$$k_p = \sqrt{\frac{\rho_k}{350}} = \sqrt{\frac{385}{350}} = 1.049$$

$$k_{mod} = 0.6 \text{ (service class: 1 / 2; load-duration class: permanent)}$$

$$\gamma_{M,T} = 1.3$$

$$F_{Z,Rd} = \frac{12.6 \cdot 1.049 \cdot 0.6}{1.3} = 6.1 \text{ kN}$$

design value $F_{Y,RD} = 0.97 \text{ kN}$

- Force direction upward:

design value $F_{Y,RD} = 0 \text{ kN} \quad (B3a)$

BB-beam connectors

Specification of essential characteristics

Design values of load-carrying-capacities – Example of calculation

Annex 3.4

BB-Balkenverbinder
Installation of the connection

Screws 5.0 x 80 mm according to EN 14592 turned in with complete thread under 35° to the grain of the joist.

Side view *)

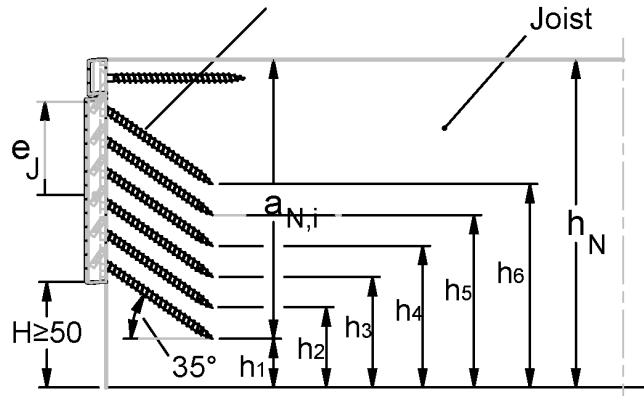
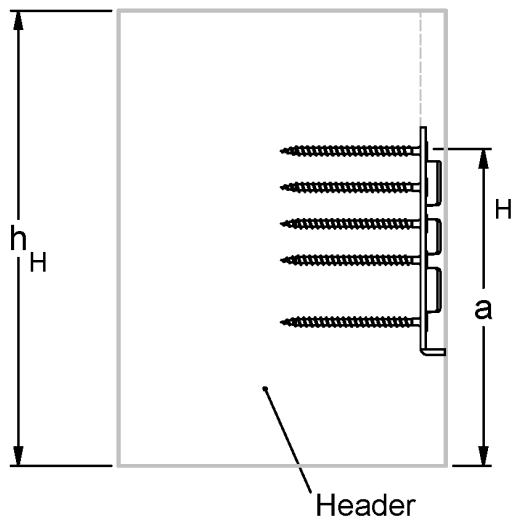

Top view *)

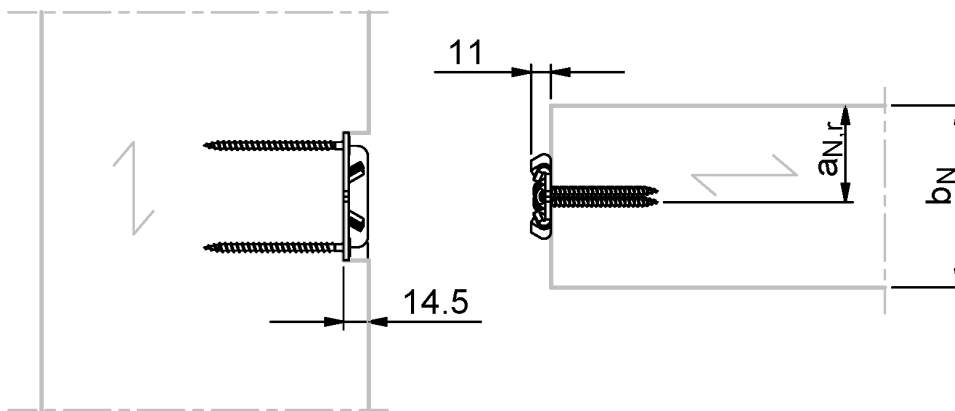

e_J ... Eccentricity of the lateral force $F_{y,Ed}$ with regard to the centroid of the joist connection.

*) an installation is shown, where the connector has been recessed in the header. The connector may also be directly screwed to the header, without recessing it.

Dimensions in mm

BB-beam connectors	Annex 4.1
Typical installations	

Side view

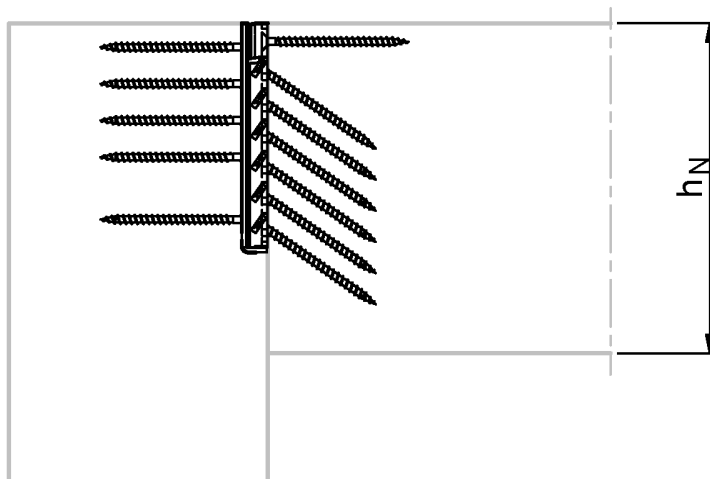

Top view

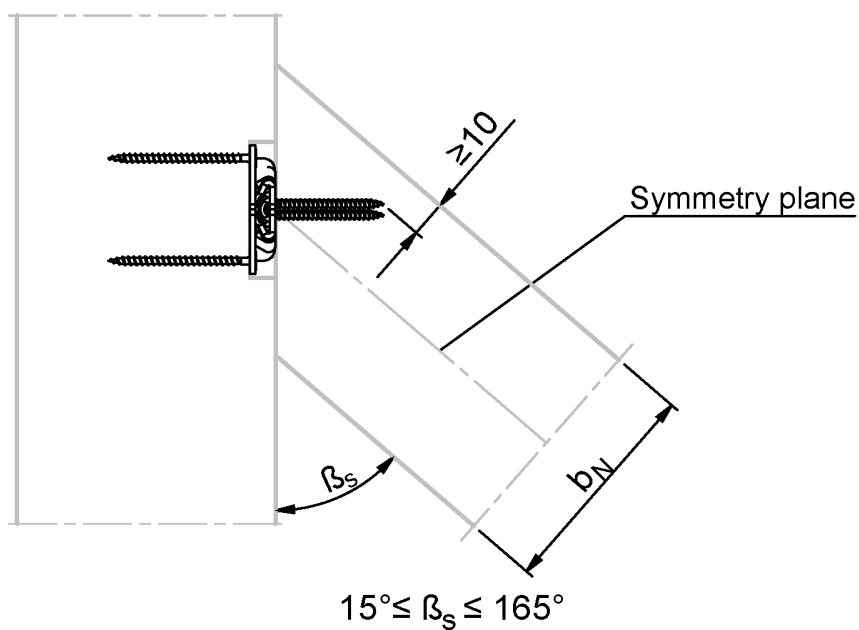

Dimensions in mm

BB-beam connectors beam connectors

Typical installations

Annex 4.2

Side view

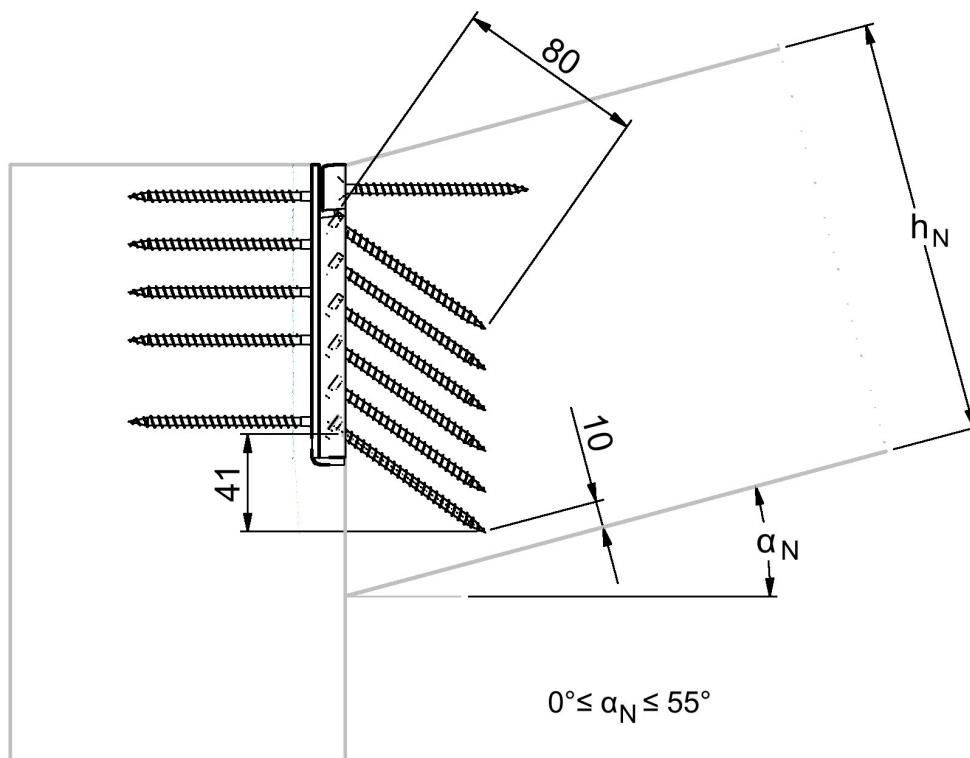

Dimensions in mm

BB-beam connectors beam connectors

Typical installations

Annex 4.3